

HANG DOOR– If **surface mounted hinges** are used, shim the door in the opening leaving 1/8" clearance at the top of the door and equal spaces along each side (but not more than 3/16" at lock edge). Use wedges at the bottom of the door to hold it in place. Carefully align the hinges on a common vertical line then drill through the door with a 1/4" diameter bit, using each hinge as a drilling template. Counterbore the hinge holes from the back side of the door with a 3/8" diameter bit to a depth of 1/2". Use the thru-bolts and grommet nuts supplied with the hinges to hang the door.

If **mortised hinges** are used, screw holes are factory predrilled on doors using standard Tiger Door hinge locations. Use only Tiger Door supplied screws to hang the door– not the short screws furnished with the hinges.

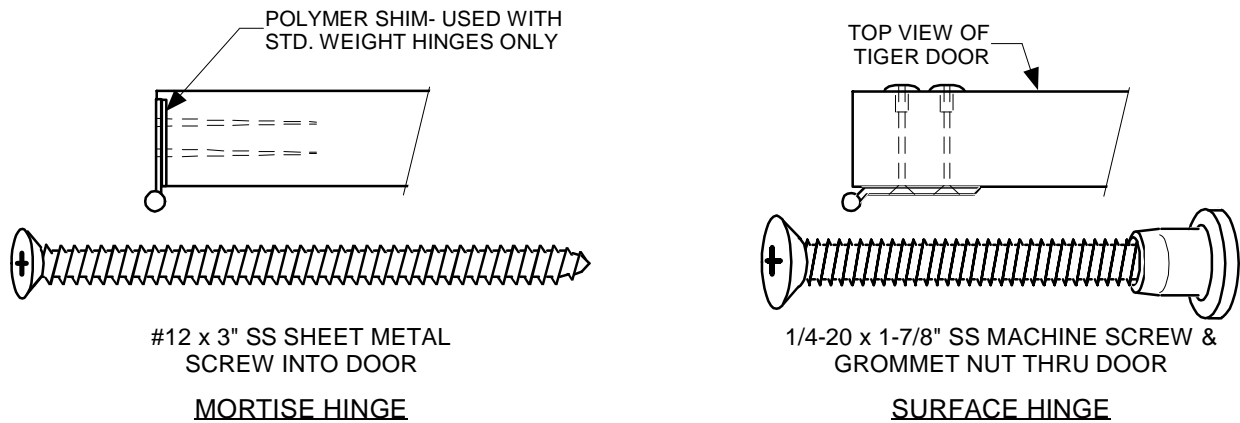

TYPES OF HINGES WITH FASTENERS REQUIRED FOR FRP DOORS

ALL DOORS ARE MACHINED FOR HEAVY WEIGHT HINGES. Polymer shims are pre-installed on the doors when standard weight hinges are to be used. Use one shim underneath each hinge.

INSTALL BALANCE OF HARDWARE ITEMS at identified reinforcement locations and adjust as necessary for proper door fit and operation. Install threshold, then weatherstripping, only after all else has been completed.

07/23/04